

Parts

Pro Plus A45 Model 16E665

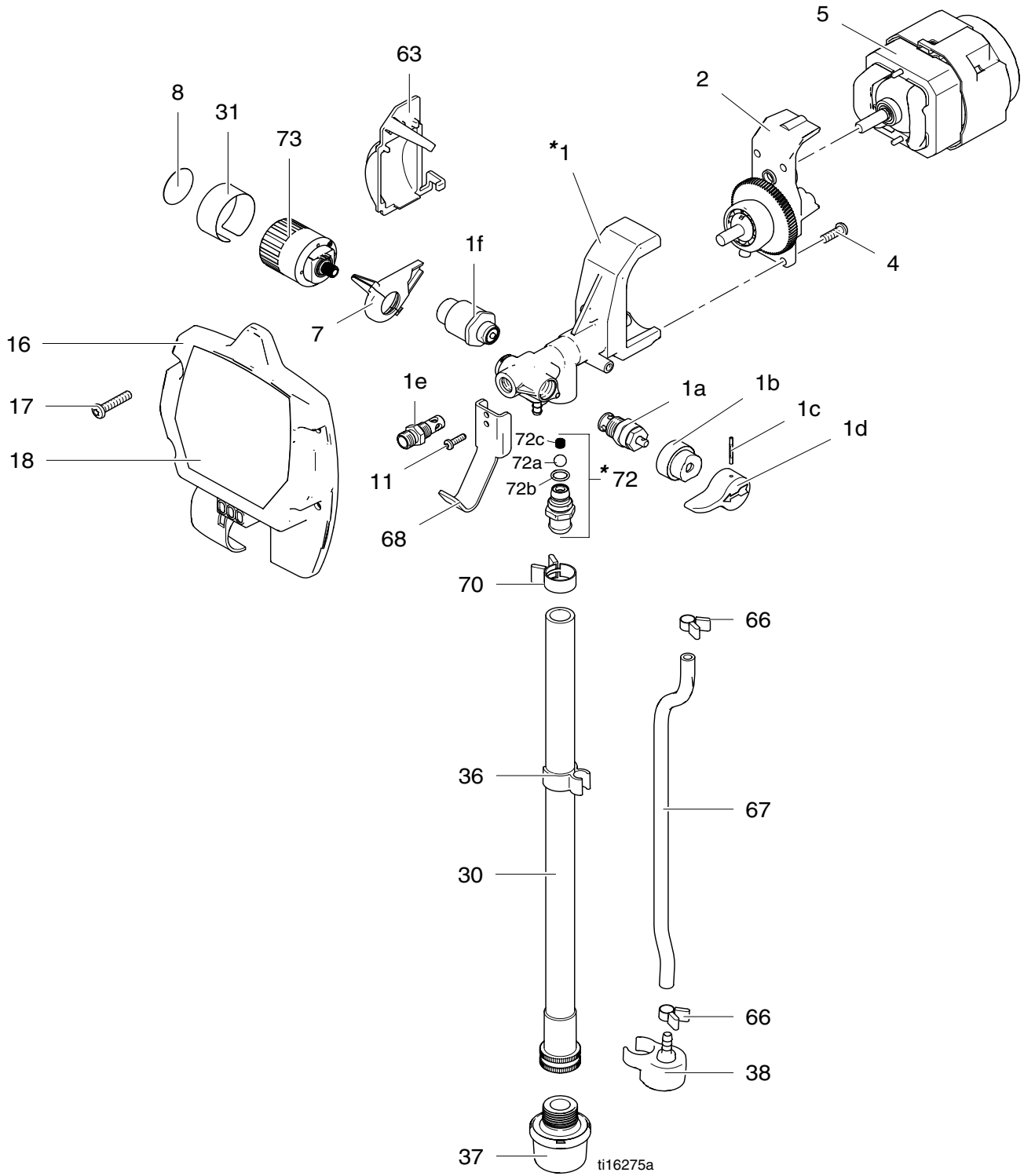

Parts List

Pro Plus A45 Model 16E665

Ref.	Part	Description	Qty.	Ref.	Part	Description	Qty.
*1	16G227	PUMP, assembly, magnum, 240V *(includes 72, 72a, 72b, 72c)	1	36	195400	CLIP, spring	1
1a	235014	DUMP VALVE	1	37	195697	STRAINER	1
1b	24E578	BASE, valve	1	38	244035	DEFLECTOR, barbed	1
1c	111600	PIN, grooved	1	63	24E510	COVER, gear	1
1d	187625	HANDLE, valve, drain	1	66	115489	CLAMP, drain tube	1
1e	16F292	VALVE, outlet	1	67	195108	TUBE, drain	1
1f	16F621	MODULE, ball knocker	1	68	16D907	HANGER, pail	1
2	16E778	HOUSING, drive, Johnson/9.6	1	70	116295	CLAMP, tube	1
4	112689	SCREW, button HD	4	*72	16F291	HOUSING, inlet (includes 72a, 72b, 72c)	1
5	16G228	MOTOR, magnum, RPX, 230V	1	72a	124249	BALL	1
7	15Y296	COVER, wire	1	72b	103338	PACKING, o-ring	1
8	15A464	LABEL, control	1	72c	123849	SPRING, compression	1
11	115477	SCREW, mach, torx pan hd	6	73	246286	CONTROL, pressure, diaphragm	1
16	16F629	COVER, housing	1				
17	120724	SCREW	4				
18	16F803	LABEL, pro plus, A45, 240V, front	1				
30	16D951	TUBE, suction	1				
31	16F635	LABEL, control, magnum	1				

▲ Replacement Danger and Warning labels, tags, and cards are available at no cost.

Parts

Pro Plus A45 Model 16E665

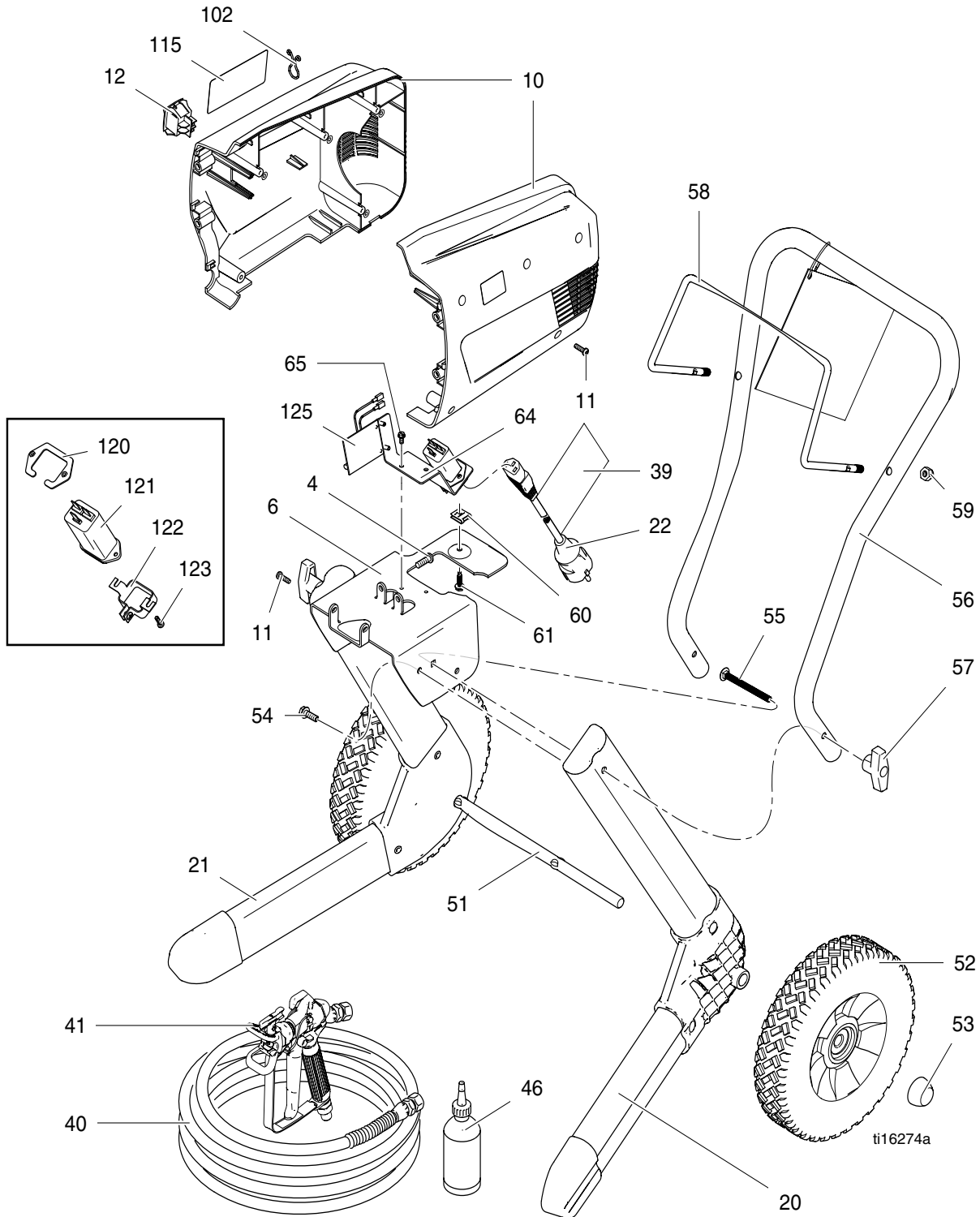

Parts List

Pro Plus A45 Model 16E665

Ref.	Part	Description	Qty.	Ref.	Part	Description	Qty.
4	112689	SCREW, button HD	4	57	115480	KNOB, t-handle	2
6	16D685	FRAME	1	58	257326	RACK, hose, painted	1
10	16G224	ENCLOSURE, sprayer (black)	1	59	120689	NUT, hex, acorn, 5/16-18, nickel	2
11	115477	SCREW, mach, torx pan hd	6	60	121481	NUT, u-type, tinnerman	1
12	118899	SWITCH, rocker, spdt	1	61	120093	SCREW, self drilling	1
20	257569	LEG, left	1	64	16F567	BRACKET, control board/EMI filter	1
21	257568	LEG, right	1	65	115492	SCREW, mach, slot hex wash hd	4
22	16G226	CORD SET, 2M, Europe	1	91▲	243308	LABEL, set int'l	1
39▲	15T069	LABEL, Magnum warning ENG/FRE/SP	1	102	121423	RETAINER, wire	1
40	HSE1450	HOSE, cpld, 1/4 in. X 50 ft	1	115▲	195793	LABEL	1
41	246506	GUN, spray, SG3-E (unpackaged)	1	120	15A467	BRACKET, filter	1
46	244168	FLUID, pump armor, 8 OZ	1	121	245648	FILTER, EMI	1
47▲	179960	SIGN, warning	1	122	115632	CLAMP, power cord	1
51	15R602	AXLE, cart	1	123	117219	SCREW, m3	1
52	115095	WHEEL, 9 in.	2	125	16G223	KIT, control board	1
53	112612	CAP, hub	2				
54	260212	SCREW, hex washer hd, thd form	4				
55	120788	SCREW, carriage	2				
56	256993	HANDLE, painted	1				

▲ Replacement Danger and Warning labels, tags, and cards are available at no cost.